

M3 ELECTRICAL AIR CONDITIONING

Gruppo Condizionatore a tetto Elettrico 48 Volt

48 Volt Electric Rooftop Air Conditioning Unit

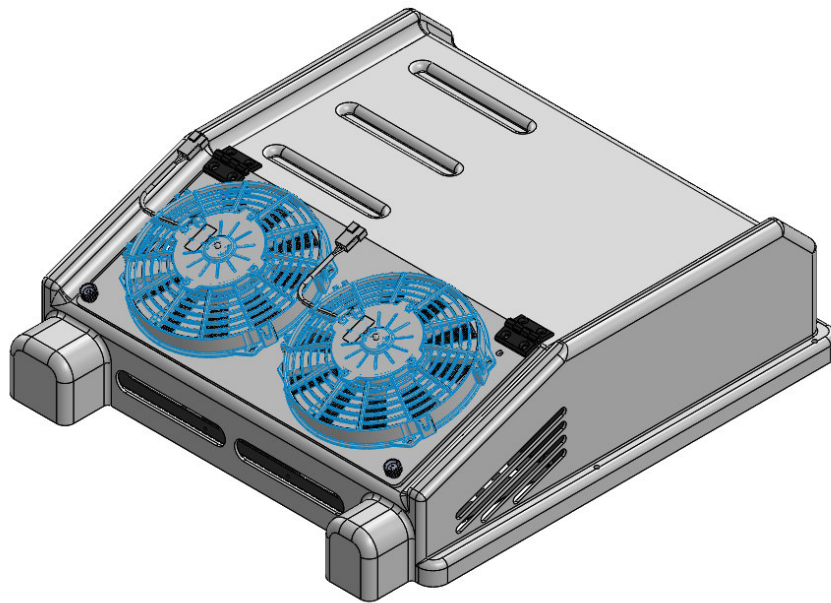

Posizione in cabina – Position in the Cabin

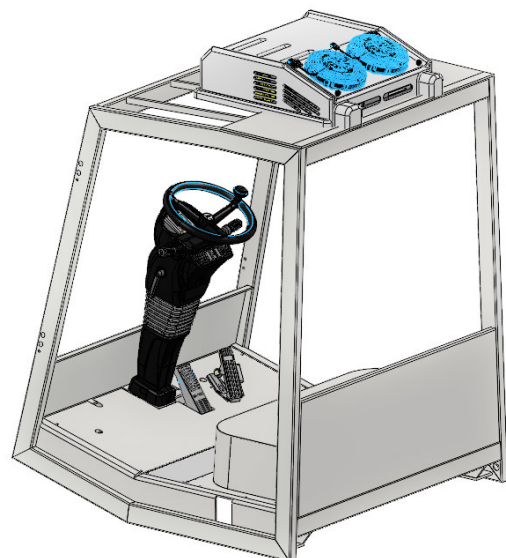
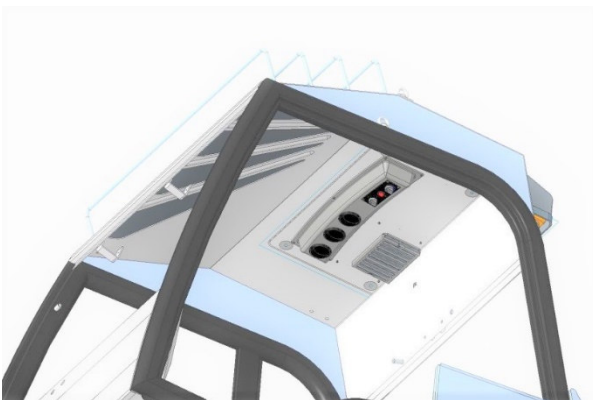

VAC AC Electrical Units

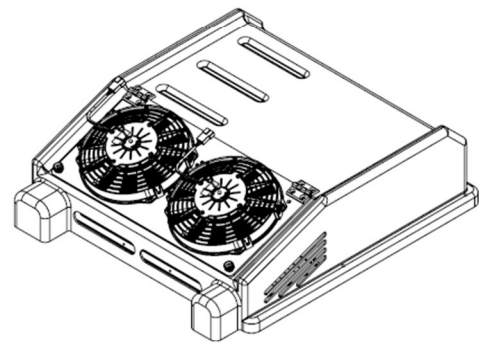
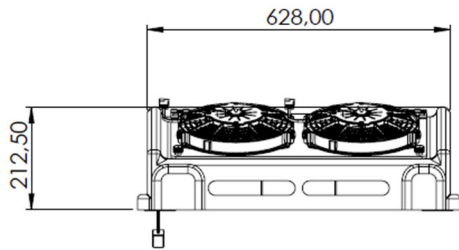
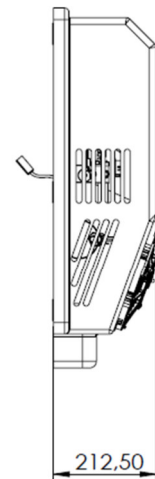
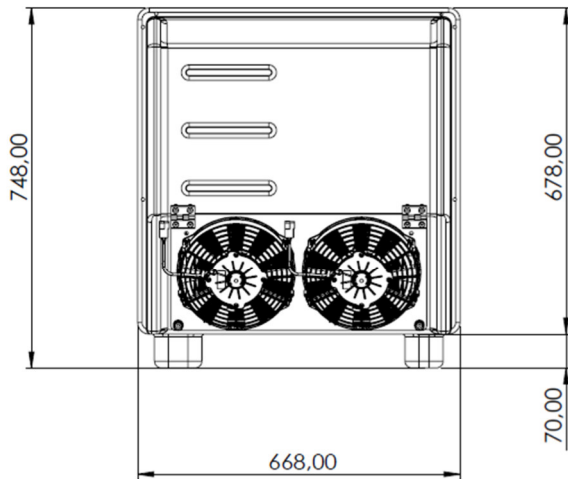

ELECTRICAL VAC AIR CONDITIONING

Gruppo condizionatore a tetto elettrico - Electric roof-mounted air conditioning unit

Codice Componente – Component Code	U98FF Version 48V@24V
	U94FF Version 48V@12V
Classe di protezione – Protection Class	IP44
Potenza in raffreddamento @+40° Cooling Power @+40°	3.5 Kw
Portata Aria (bocca libera) AirFlow (free mouth)	530 m3/h
Assorbimento Elettrico Power consumption	Servizi @12V= 28Ah - @24V=18Ah – Services @12V= 28Ah - @ 24V = 18Ah Condizionamento 48V= 25Ah – Air conditioning 48V= 25Ah
Velocità ventilatore Ventilation Speed	3
Refrigerante - Refrigerant	R134a (incluso – included)
Peso - weight	31 Kg
Note Notes	