

TRIESTE 9Kw

Condensatore ventilato con ventola aspirante.

Ventilated condenser with suction fan.

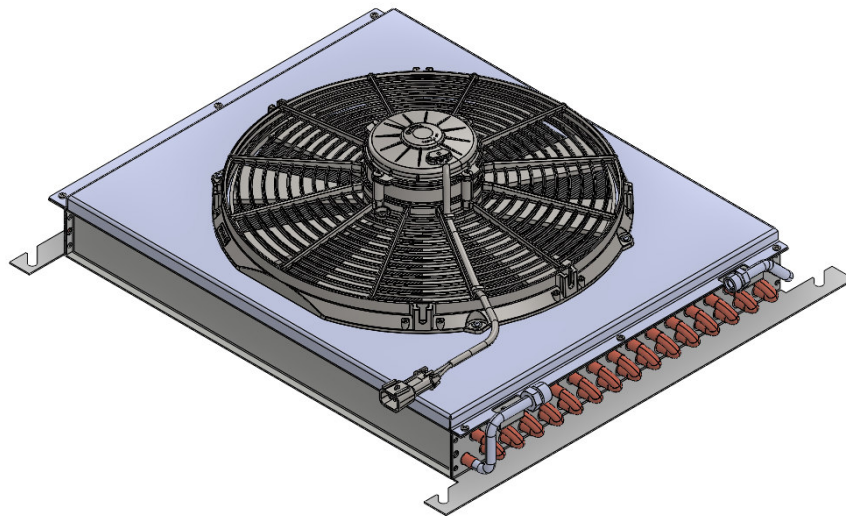

Posizione in cabina – Position in the Cabin

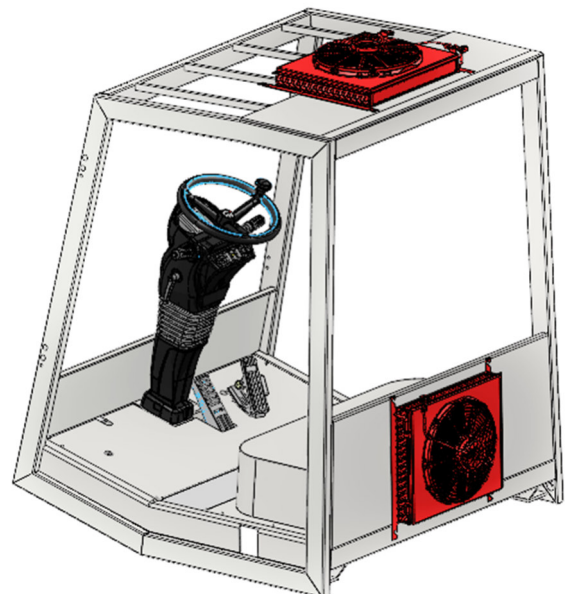

Electroventilated Condensers

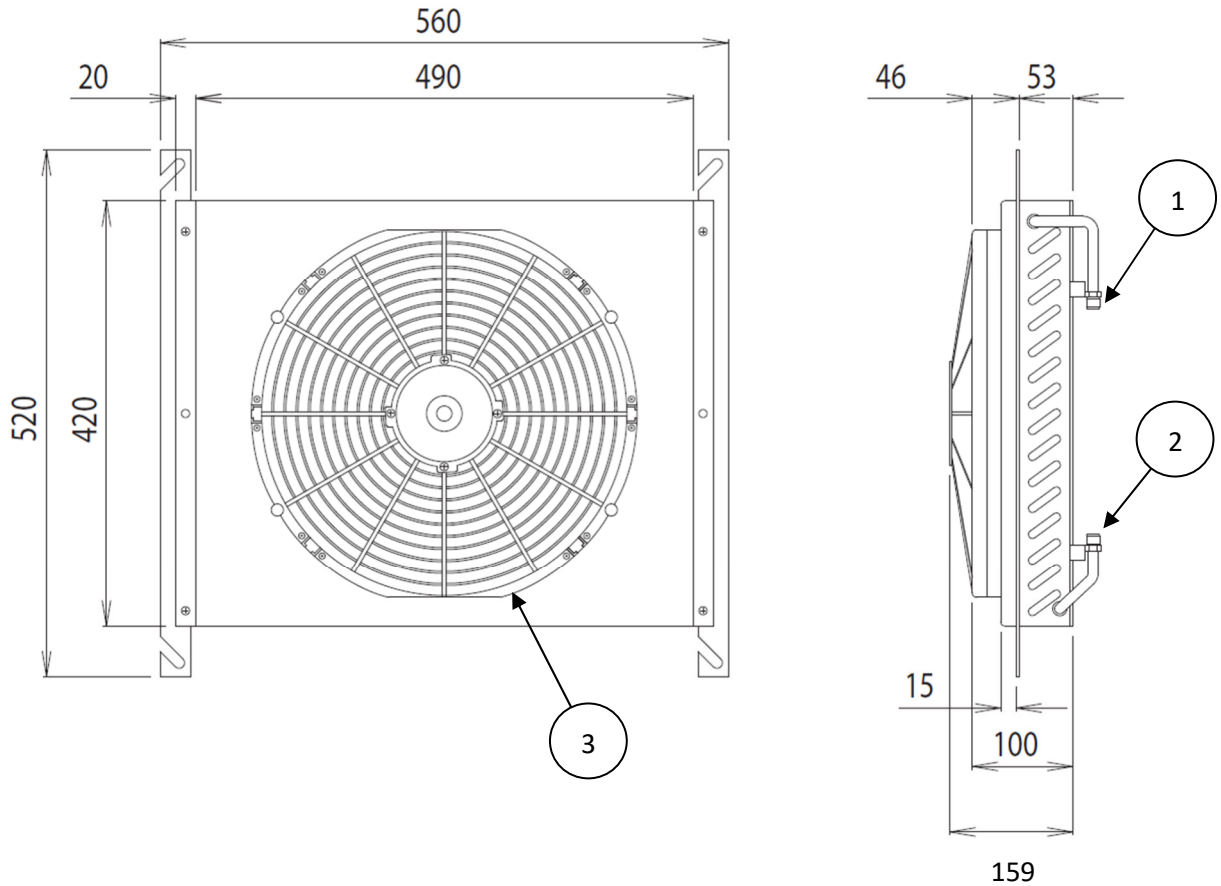

TRIESTE 9Kw

(IT) - Condensatore ventilato con ventola aspirante.

(GB) - Ventilated condenser with suction fan.

Codice Componente – Component Code	025065.12V Version 12 Volt 025065.24V Version 24 Volt
Corrente Assorbita Current Draw	@ 12V = 21Ah - @24V = 11Ah
Pos. 3 = Connessione Elettrica Pos. 3 = Electrical Connection	Connettore AMP TIPO F Cod.180908 Connector Type F AMP P/N 180908
Potenza Termica dissipabile +40° Dissipable Thermal Power @ +40°	9 Kw
Portata Aria AirFlow	3160 m3/h Aspirante - Suction
Tipo di condensatore Condenser Type	Tubo rame alettato P2,5 mm Finned Copper Tube P2,5 mm
Posizione di montaggio Mounting Position	Orizzontale – Orizortal Verticale - Vertical
Pos. 1 = Connessioni tubi Pos. 2 = Hose Connection	IN= 3/4"-16UNF-2A OUT= 5/8" -18UNF-2A
Refrigerante - Refrigerant	R134a
Peso - weight	9 Kg